

Manual For FaceEngine 8/T8

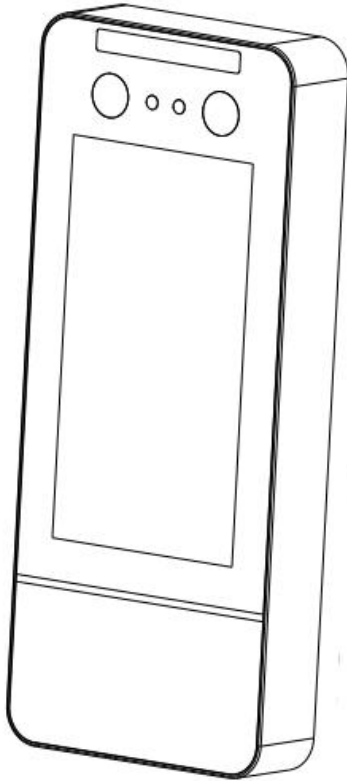

Note: The picture is for reference only, please refer to the actual product

Dear users, thank you for choosing our products. We will serve you with high-quality products to ensure that you use this product more smoothly. Please read this manual carefully before using it!

Wiring Diagram:

☆Wiring diagram

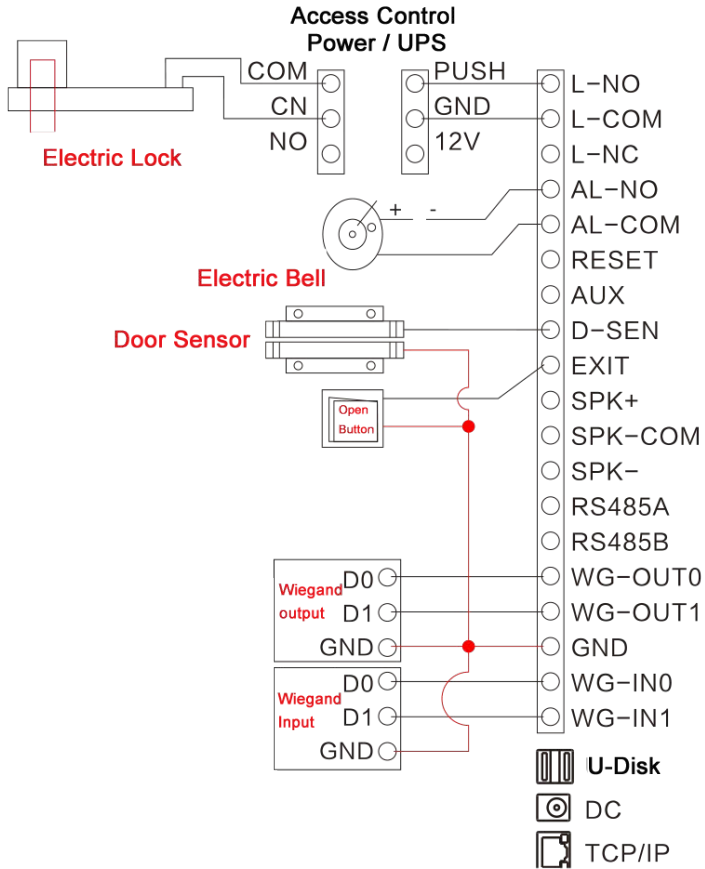

2.2 Device Installation Steps:

- (1) Choose an appropriate face recognition height to determine the installation height of the device. After the installation height is determined, drill wire holes and fixing holes.
- (2) Use a screwdriver to remove the screws at the bottom of the fuselage (Picture 1)
- (3) Separate the equipment from the mounting plate (Picture 2)
- (4) Fix the mounting plate on the wall (Picture 3)
- (5) Align the bayonet of the bottom cover of the device with the mounting plate and pull it down into the mounting position (Picture 4)
- (6) Fix the device with the bottom cover with screws (Picture 5)

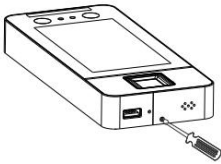

Picture 1

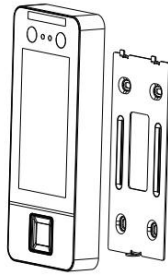

Picture 2



Picture 3

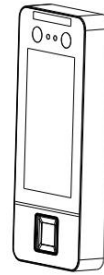

Picture 4

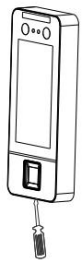

Picture 5

1. Enter Main Menu

Enter Menu and select “User”

In the initial interface, click the setting icon  in the lower right corner. If you set up an administrator, you need to identify the administrator to enter.

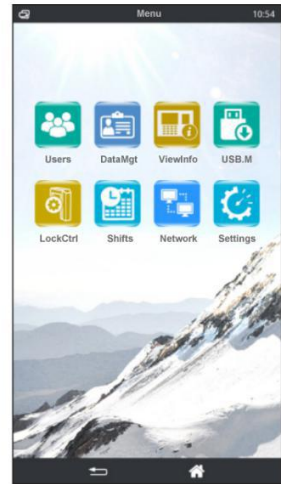

2. User Management

(1) User Registration

Click "Users" , and "  " at the bottom of the screen (Picture 1), enter the User ID and name and click " ✓ ". Then collect employee characteristics for registration (Picture 2).

(2) Search User

Click "Search" in the upper right corner (Picture 1), enter the User ID or name and click " ✓ " for precise search.

(3) User Modify

Click on the user that need to be modified, enter the "modify" interface to modify, re-record, and delete the user's basic information and user permissions (Picture 3).

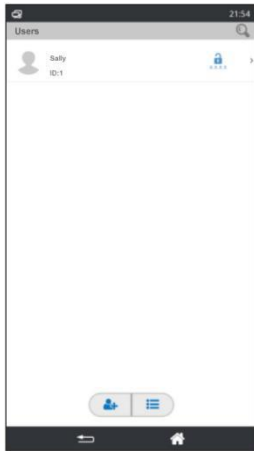

Picture 1

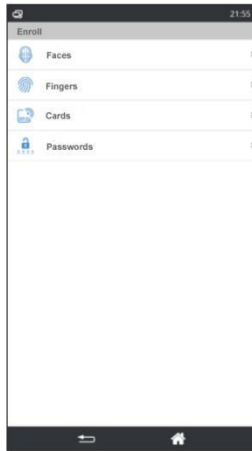

Picture 2



Picture 3

3. Data Management(DataMgt)

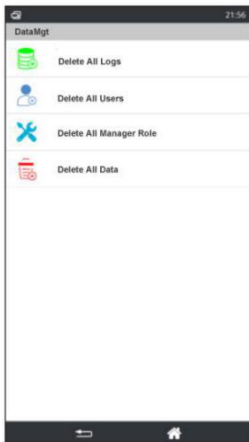

(4) User Registration

Click "DataMgt" to delete all logs, all users, all Manger Role or all data, password is 8282.

Delete All Logs	Delete all logs
Delete All Users	Delete all user & registration data
Delete All Manager Role	Delete all administrator rights, but keep registration data
Delete All Data	Delete all registration data and logs

4. View Information(ViewInfo)

(1) User Log

Click “ViewInfo” → “User Log” → Enter User ID → Select the time period → User Log, you can search all logs of this user ID during this time period. If you don’t input the user ID, only selecting the time period, you can search all logs of all users during this time period.

(2) Reg.Info

Click “Reg..Info”, you can check basic registration information of the device

(3) Dev.Info

Click “Dev.Info”, you can check MFG, Web Site, Serial No., Mfg.Date, Model Name, Firmware version and Engine.

5. Download/Upload Data by USB(USB.M)

(1) USB Download

Click “USB Download”, you can download data or report to U-disk, to prevent data lose and facilitate the upload of data in the future

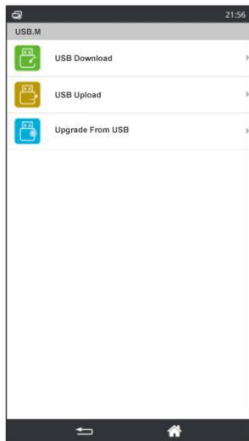

(2) USB Upload

Click “USB Upload”, you can upload the user information from U-disk to multiple devices, no need to re-enter all user information.

(3) Upgrade From USB

Steps:

- A. Copy the firmware that needs to be upgraded to the U-disk;
- B. Insert the U-disk to USB port;
- C. Click “Menu” → “USB.M” → “Upgrade From USB” → “OK”;
- D. The device will restart automatically after upgrading successful.

☆ The firmware must be same series, with same firmware name in the device

6. Access Control Setting(LockCtrl)

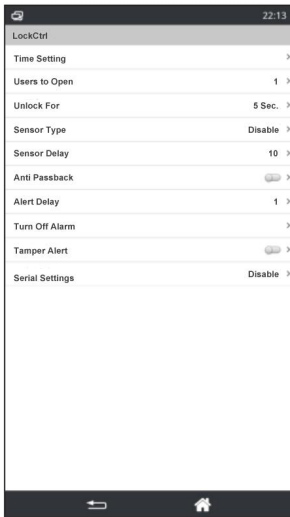

Click “LockCtrl” to enter access control setting(Time Setting, Users to Open, Unlock For, Sensor Type, Sensor Delay, Anti Passback, Alert Delay, Turn Off Alarm, Tamper Alert, Serial Settings)

Time Setting:	The definition of the time interval for unlocking every day
Users to Open:	Require how many users to confirm before they can open the door at the same time
Unlock For:	Time for device control the time to open or closed the electric lock
Sensor Type:	The type of door magnet: there are three types: No, Open Type, Closed Type; “No” does not use the door switch, “Open Type” refers to the case of the door closed normally open magnet, “Closed Type” under the door magnet is closed.
Sensor Delay:	After open or close the door, the time to start detecting door status, default 10second, max 255seconds
Anti Passback:	Prevent trailing out, Yes/No
Alert Delay:	After triggering tamper switch of the machine, start alarm if over the delay time
Turn Off Alarm:	When the alarm is on, and it has been ruled out that it is not an illegal operation. You can stop the alarm by this option
Tamper Alert:	Turn on or off the alarm signal when the machine is dismantled
Serial Settings	RS485 fingerprint reader

7. Shifts

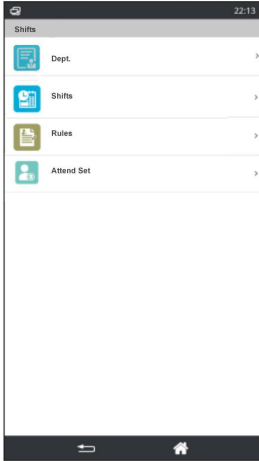

(1) Dept.

Click “Dept” to set shifts for department.

(2) Shifts

Click “Shifts” to set shifts.

* Can not set shifts for device with more than 5,000users

(3) Rules

Click “Rules”, you can set the time allowed to be late and the time allowed to leave early.

(4) Attend Set

Click “Attend Set”

Verify Mode	FC:face, P:password, C:ID/IC card, personal
Punch Interval	During this repeated confirmation time(minute), only the keep the earliest piece of useful data from the user
Continuous Match	Turn off continuous match, only recognize once when the face does not leave the recognition range
AVL Logs Alert	Set this value to achieve a warning sound when the maximum recording capacity is approaching
Stranger Record	Open the stranger record, and save the identification time and identification photos of unregistered people

*Personal: You can set different confirmation methods for each person in Menu → Users → Other Settings → Verify Mode

8. Network

Click "Network" to enter the network settings (you can set the Dev. Name, ETH, WiFi, Port No. Net PWD, Server IP, Server Port, Push Server IP, Push Server Port, Real Time Req., NTP Address).

※ When you need to start real-time monitoring, you must set the corresponding "Server IP" and "Server Port", and open "Real Time Req.".

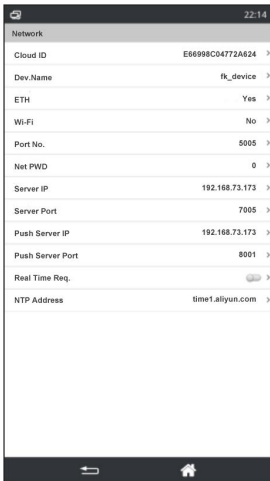

(1) **ETH:** Click "ETH" to enter the Ethernet setting interface, and select "Enable" (default Ethernet is open), then configure the IP Address, Net mask, and Gateway according to the actual network environment.

(2) **Wi-Fi:** Click "Wi-Fi" to enter the wireless network setting interface, select "Enable" to turn on the wireless network communication function, then select automatic acquisition or manual setting of IP, enter "Search", select the WIFI signal to connect to, and enter the password to connect to wireless The internet.

9. Settings

(1) Date and Time

Click "Date and Time" to revise the Date & Time in the device. You can also select "Auto SyncTime". After the device is connected to the network, it will automatically synchronize the time to the device.

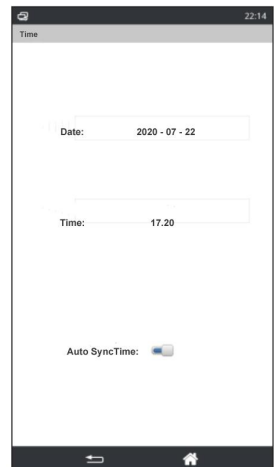

(2) Display

Verified Screen	After the attendance check-in is successful, the time that the display interface returns to the initial interface.
Screen Saver	The exceeded time for the machine in stand by mode and enter the screen saver mode
Sleep Time	When the machine is in the screen saver state for more than this time, the screen is turned off, and the face can be detected or touch the screen to wake up
Bright Led	Turn on or off the fill light

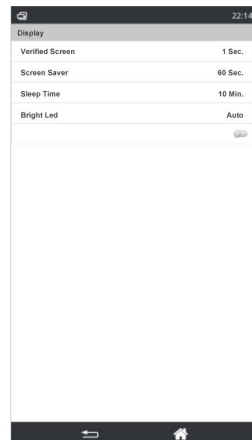

(3) Volume

Click "Volume" to adjust the volume.

(4) Set Bell

Click "Set Bell" to set the time and frequency of ringing.

(5) Wiegand

Wiegand Format	Wiegand protocol input and output signal is Wiegand 26 or Wiegand 34
Wiegand Output	The Wiegand protocol outputs the User ID. or Card Number.
Wiegand Input	The Wiegand protocol inputs the User ID. or Card Number.

(6) Bio Set

Click "Bio Set!" to open or close the Live Detection.

(7) Language

Click "Language" to switch languages.

(8) Testing

Sunlight	Infrared camera image detection
Test Color Image	Color camera image detection
Test Color and Infra Image	Dual camera image detection

(9) Reboot

Click "Reboot" and then click "OK" , the machine will restart automatically.

(10) Reset Default

Click "Reset Default" and then click "OK" to initialize some parts of the settings.

※Reset Default will not clear user data and attendance logs!